



深圳市蓝宝安科电子有限公司

Shenzhen LanbaoAnke Electronics Co.,Ltd.

承认书

APPROVAL SHEET

编号 NO.	LB-DPG-02
版次 Ver.	A/2

客户 Customer	
-----------------------	--

品名 Product	三端保险丝
系列 Series	DPGxx30 Series

料号Part No.	规格描述Specification	备注Remark
蓝宝 LB fuse		
客 户 Customer		

供应商-蓝宝 Supplier-LB fuse		零件承认章 Approval Signet	客户 Customer	零件承认章 Approval Signet
制作 Make				
审查 Check				
批准 Approval				

联络Contact			
业务Sales	电话Telephone	手机Cellphone	邮箱E-mail
			lanbaofuse@163.com

零件承认后敬请回签一份给我司留存。

History of Change变更记录

NO.	日期 Date	描述 Description	版次 Edition	修改 modified by	审核 Checked by
1	2020.05.20	新制订	A/1		
2	2023.04.03	更改为新封面	A/2		
3					
4					
5					
6					
7					
8					
9					
10					
11					

1. 适用范围 / SCOPE

DPG 系列三端保险丝，保护锂离子电池免受过电流和过电压的影响，适用于一般电子设备。

DPG Series Resistor Embedded Protector, Protect Li-ion battery from the overcurrent and the overcharge

2. 产品编码标示/ Part Numbering Marking

例「example」:

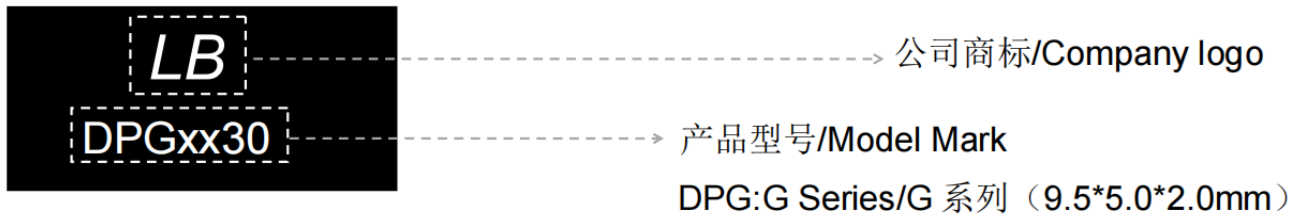

3. 电气特性 / ELECTRICAL CHARACTERISTICS

Part Number	I _{rated} (A)	Cells in series	V _{max} (V _{DC})	I _{brek} (A)	V _{op} (V)	R _{fuse} (mΩ)	Agency Approval
							C UL US
DPG0430	30	1	120	80	4.0 ~ 6.6	1.0 ~ 2.5	E213695
DPG0830	30	2	120	80	5.6 ~ 9.0		
DPG1230	30	3	120	80	8.4 ~ 13.2		
DPG2030	30	4~5	120	80	10.5 ~ 23.5		
DPG3030	30	6~7	120	80	20.2 ~ 31.5		
DPG3230	30	8	120	80	26.4 ~ 36.0		
DPG4030	30	10~14	120	80	28.0 ~ 62.0		
DPG4030-2	30	12	120	80	33.6 ~ 54.0		
DPG4030-3	30	13	120	80	36.2 ~ 58.5		
DPG5030	30	15~17	120	80	42.0 ~ 74.8		
DPG5030-20	30	20	120	80	70.0 ~ 90.0		
DPG5030-22	30	22~27	120	80	72.0 ~ 120.0		
DPG5030-36	30	36	120	80	90.0 ~ 133.2		
DPG3230-P	30	8 LFP	120	80	20.0 ~ 30.0		
DPG4030-P	30	14 LFP	120	80	35.0 ~ 51.8		
DPG5030-1P	30	15 LFP	120	80	37.5 ~ 55.5		
DPG5030-2P	30	16 LFP	120	80	36.0 ~ 62.0		
DPG5030-3P	30	17 LFP	120	80	42.5 ~ 62.9		
DPG5030-6P	30	20 LFP	120	80	50.0 ~ 74.0		
DPG5030-9P	30	23 LFP	120	80	60.0 ~ 85.0		
DPG5030-8P	30	22~24 LFP	120	80	55.0 ~ 87.6		

注解 / Annotation:

额定电流 I_{rated}: 40°C 热平衡环境温度下保险丝可以正常工作的电流。

Current carrying capacity that is measured at 40°C thermal equilibrium condition

分断电流 I_{brek}: 保险丝可以正常切断的最大安全电流。

The current that the fuse element able to interrupt

最大电压 V_{max}: 保险丝可以正常切断的最大安全电压。

the maxmum Voltage that can be cut off by fuse

工作电压范围 V_{op}: 保险丝可以正常工作的电压范围。

Range of operation voltage

保险丝电阻 R_{fuse}: 保险丝元件的电阻

The resistance of the fuse element

串联单元/Cells in series: 电池串联数量

Number of battery cells connected in series in the circuit for ITV device to protect

4. 产品工程图/测试基板尺寸 / OUTLINE DRAWING&TEST SUBSTRATE SIZE

4-1 工程图（单位：mm） / Outline Drawing (Unit: mm)

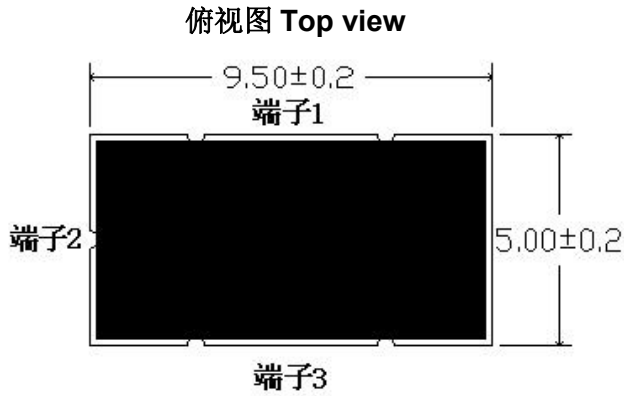

等效电路 Equivalent Circuit

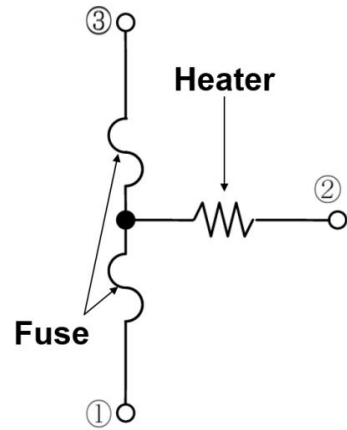

侧视图 Side view

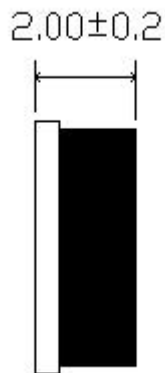

底视图 Bottom view

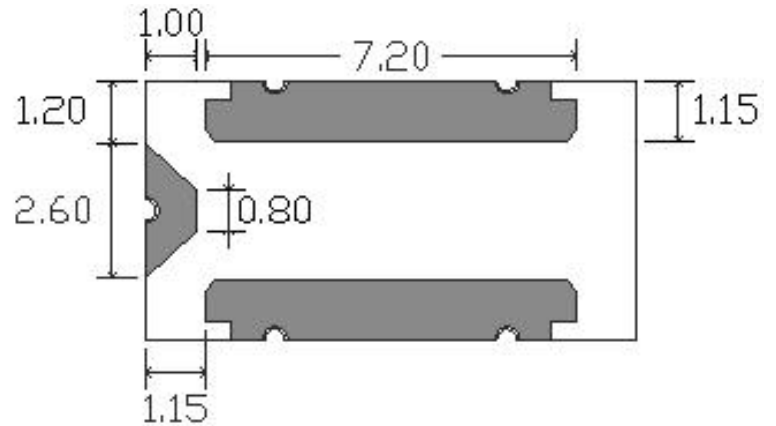

表面外壳为 LCP 材料，底部基板为氧化铝陶瓷

The surface shell is made of LCP material, and the bottom substrate is made of alumina ceramics

除非另有指定，外部尺寸公差为： ± 0.2 mm。

Tolerances Unless Otherwise Specified: ± 0.2 mm.

4-2 测试基板尺寸 (单位: mm) / Test substrate size (Unit: mm)

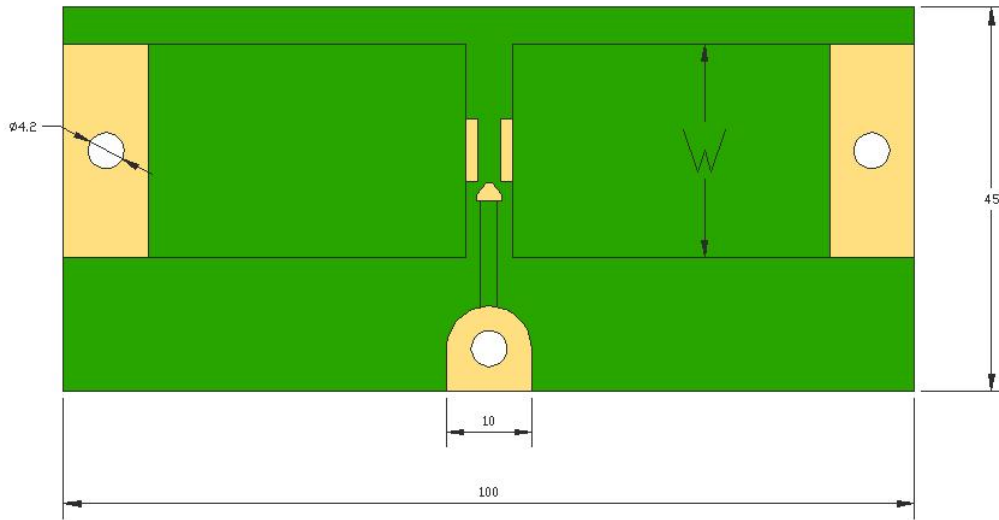

使用无铅焊料 (Sn96.5/Ag3/Cu0.5 [%]) 将产品焊接到规定的测试板子 (Fig 1) 上, 使用包覆线 (L=15cm) 分别连接测试板的 1、3 端与电源的输出端。

Fuse links are soldered to the prescribed circuit board (Fig 1) with Pb-free solder (Sn96.5/Ag3/Cu0.5 [%]). Covered wires(L=15cm) that provides to Table.1 are soldered to the board's Terminal①,③ by the solder above.

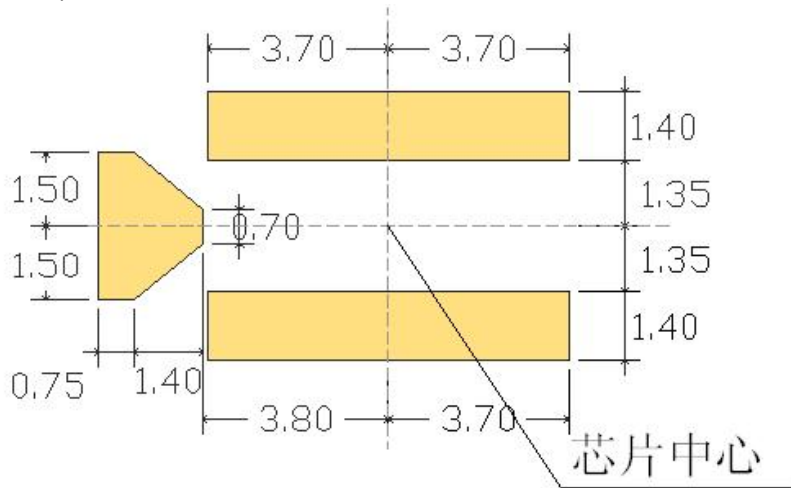

注:

这仅是建议的焊盘尺寸, 并不保证贴装质量。请结合贵公司的设计指南进行验证。

This is only the recommended size and does not guarantee the mounting quality. Please verify it in combination with your company's design guidelines.

额定电流 Rated Current	材质 Materials	基板厚度 Base thickness	铜箔宽度W Copper width W	铜箔厚度 Copper thickness	包覆线型号 Covered wires
30A	环氧玻璃印制线路板 Glass Epoxy PWBs.	0.6-0.66mm	6mm	2.0OZ	AWG10

5. 产品性能曲线/PRODUCT PERFORMANCE CURVE

5-1 I-t图/CHARACTERISTICS DIAGRAM(I-t)

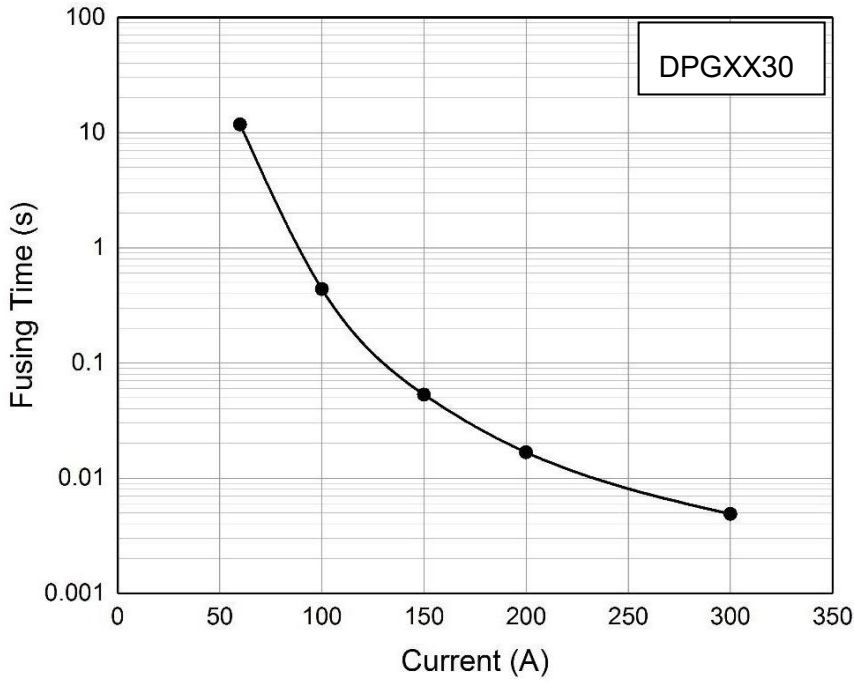

5-2 2倍I-t图/CHARACTERISTICS DIAGRAM(2*I-t)

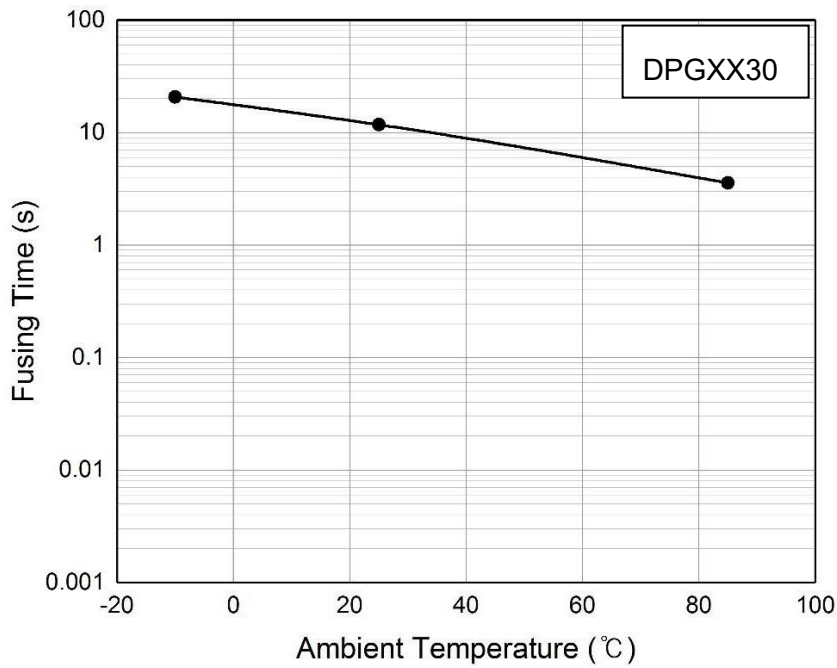

5-3 加热体功率与熔断时间曲线图/CURVE OF HEATING ELEMENT POWER AND FUSING TIME

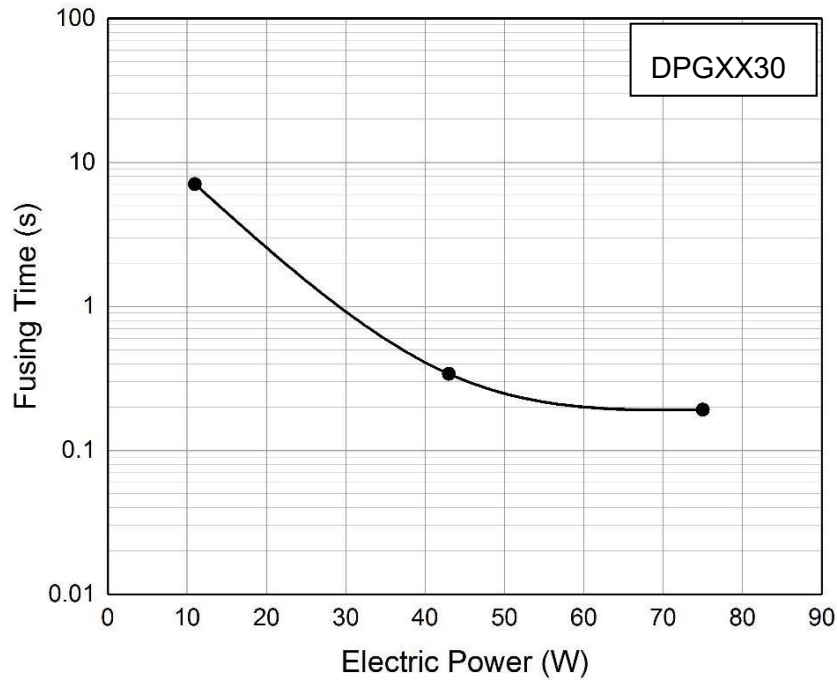

5-4 不同功率/环境温度下熔断时间曲线/FUSING TIME CURVE UNDER DIFFERENT POWER / AMBIENT TEMPERATURE

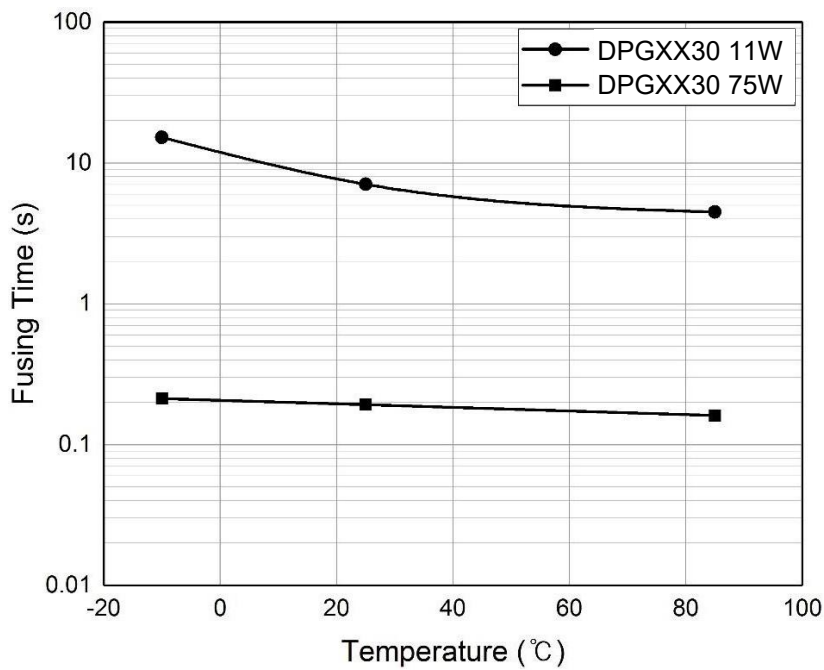

5-5 电流与环境温度曲线/CURRENT ANE AMBIENT TEMPERATURE CURVE

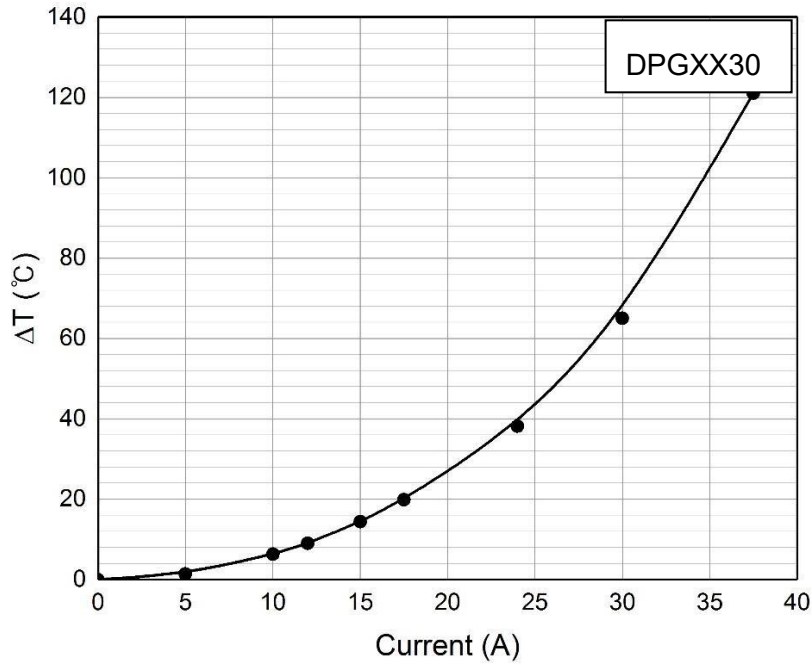

6. 建议客户焊接参数 / RECOMMENDED CUSTOMER SOLDERING PARAMETERS

6-1 回流焊曲线/REFLOW

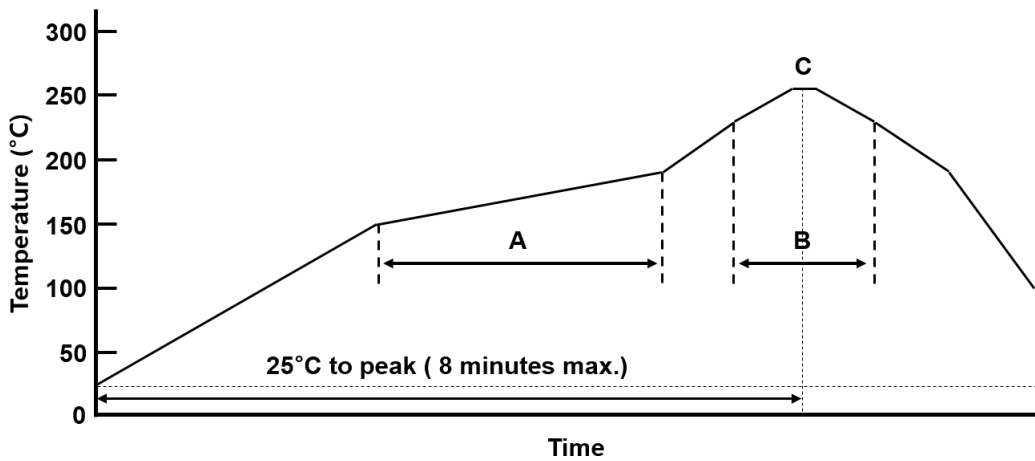

	A (预热段/Pre-Heating)	B	C (最高温度/Peak)
Temperature [°C]	150~190°C	Over 230°C	255 ± 5°C
Time [sec]	90 ± 30sec	25 ± 5sec	Max. 5sec

7. 包装讯息 / PACKING INFORMATION

7-1 包装数量、重量 / QUANTITY & WEIGHT

型号 Type Number	数量(pcs) Quantity(pcs)
LB-DPGxx30	2,000

7-2 卷轮规格/ Reel & Tape specifications

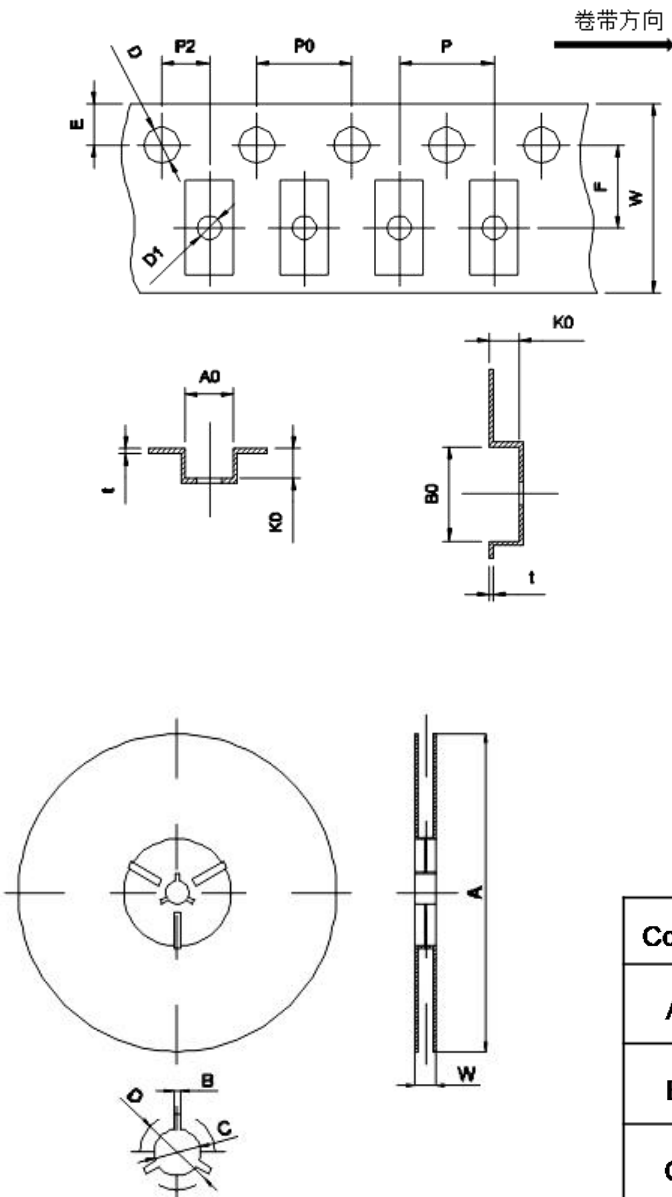

Code	(mm)
E	1.75±0.10
F	7.50±0.10
P2	2.00±0.1
D	1.50±0.1
D1	1.50±0.1
P0	4.00±0.10
10P0	40.0±0.20
W	16.00±0.30
P	8.00±0.10
A0	5.40±0.10
B0	9.85±0.10
K0	2.48±0.10
t	0.30±0.05

Code	(mm)
A	330±1.0
B	2+0.5/-0
C	13±0.2
D	21±0.2
W	21.4±1.0

8. 环境可靠性测试 / ENVIRONMENTAL RELIABILITY

项目Items	测试条件 Conditions	参考标准 Reference standard
熔断时间 Fusing time	通以2倍额定电流/Apply 200% of its rated current.	保险丝需在1分钟内断开 /The fuse shall be melt within 1min.
	产品工作电压范围的最小值应适用于发热体/The minimum value of the operating voltage range of each model shall be applied to heater.	
额定电流测试 Current carrying capacity	通以1倍的额定电流/Apply 100% of its rated current.	不能断开/No melting.
工作温度范围 Operating temperature range	分别在-10°C至65°C的环境温度下进行如下试验/The following examinations are executed respectively within the range from -10 to 65°C. •熔断时间测试/Fusing time test •额定载流测试/Current carrying capacity test	保险丝应通过每次测试 /The fuse shall be passed each test.

*电气特性受PCB板的热容量、零件、线路宽度等的影响。因此，您应该在PCB板上进行测试

Electrical characteristics are influenced by thermal capacity of PCB, parts, pattern width, etc. Therefore you should check them on your PCB.

版次	制作	确认	审核
第 1 版	赖秋莲 2022/05/20	谢海林 2022/05/20	熊士军 2022/05/20

三端保险丝使用特别说明/Handling Instructions for REP

- 请在设计前确认最新的产品信息/Please confirm the latest product information before a design.
- 储存条件/Storage Condition
 - 本产品应储存在凉爽（室温低于 40°C）和相对湿度低于 60%的干燥条件下，并远离溶剂烟雾环境。
This products should be stored in a cool (Room temperature under 40°C) and dry condition less than 60% relative humidity and kept out of solvent fumes circumstances.
 - 在稳定的储存条件下，保存期为装运后 3 个月
Under stable storage conditions the preservation period is 3 months after shipping.
- 三端保险丝应遵守的环境法规/REP complies with environmental regulation.
 - 产品符合 ROHS/REP complies with RoHS
 - 产品符合无卤素的一般要求/REP complies with general requirement for Halogen Free.
- 性能参数仅作为参考值/Performance data is typical value.
 - 这些数据并不是绝对值
These data is not a guaranteed value.
 - 这些数据均为专用测试基板测量所得
These data is measured with our company's standard PCB.
 - 特性受 PCB 基板热容量的影响
The characteristics are influenced by thermal capacity of PCB.
 - 一般来说，当 PCB 的热容量增加时，载流量会增加，熔断时间会拉长
Generally, when thermal capacity of PCB increases, current-carrying capacity will be increase and fusing time will be long.
- 处理注意事项/Precautions regarding handling
 - 请参阅“测量（第 3 页）”一节，确保本产品的端子连接在电路板的焊盘上。
Make sure that the terminals of this product are connected on the lands of the circuit board referring to section “Measurement (pp. 3)”.
 - 超声波清洗、浸没清洗等不得在安装前后进行。清洗完成后，元件上的焊剂会流动，并且不符合其规格要求，此外，当产品与清洗液接触时，也会产生类似的影响，清洁后的这些产品将无法保证。
Ultrasonic-cleaning of immersion-cleaning and so on must not be done to REP before and after mounted. When cleaning is done, flux on element would flow, and it would not be satisfied its specification. Moreover, a similar influence happens when the product comes in contact with cleaning-solution. These products after cleaning will not be guaranteed.

- 防止腐蚀性气体（Cl₂、NH₃、SO_x、NO_x等）接触产品。
Prevent corrosive gas (Cl₂, NH₃, SO_x, NO_x, etc.) from contacting the products.
- 请不要重复使用通过手工退焊取下的产品。
Please do not re-use of the REP removed by solder correction
- 由于陶瓷结构的性质，过大的应力或冲击可能会使产品破裂或开裂。
Excessive stress or shock may make products broken or cracked due to the nature of ceramics structure
- 贴片返工/SMD Re-work
 - 请不要重复使用通过 PCB 板重新焊接移除或分离的三端保险丝。
Please, Do Not Reuse the REP removed or detached by PCB re-work
 - PCB 重新焊接后，应按照以下步骤重新安装新的三端保险丝。
After PCB Re-work, Re-mounting of NEW REP should be done as follow step.
 - 加热板：温度为 220±5°C，持续 3 秒
Hot Plate: Temperature of 220 ± 5°C for 3sec.
 - 烙铁头退焊：温度为 300±5°C，持续 3 秒
Iron: Temperature of 300 ± 5°C for 3sec.